

Ux360i

UV Laser Printer



Contrast. Speed. Precision.



The Ux360i is designed for demanding, high-speed production environments. It integrates easily into production processes and, thanks to its beam flexibility and configuration options, adapts to virtually any production line.



nimax.ug

Our promise is a fully customized end-to-end marking solution, including application testing, installation, safety guards, fume extraction, automation software, visual inspection, remote monitoring, and comprehensive support.

CODING AND MARKING

IDEAL FOR MODERN PACKAGING

- The Ux360i excels on sensitive materials such as films and single-layer plastics designed for recycling.
- Coding is achieved through a photochemical reaction on the outermost layer of the packaging material, without causing damage.

OPERATIONAL FLEXIBILITY AND CUSTOMIZATION

- A printer that adapts thanks to over 50 standard beam emission options, plus customization options for specific needs.
- Operation is simple via a web-based user interface and an intuitive HMI.
- Integration with ERP, WMS, and MES systems is seamless.

YOUR PARTNER FOR A COMPLIANT SOLUTION

- The Ux360i is designed to ensure compliance with international regulatory standards (EU Annex 11 GMP, FDA 21 CFR Part 11).
- As a GS1 Solutions Partner, we provide GS1-compliant 2D coding.
- We offer validation support to ensure your production meets quality, safety, and efficiency requirements in line with GMP/GAMP.

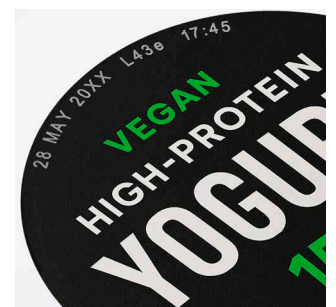

TECHNICAL SPECIFICATIONS Ux360i

Laser type	
Laser technology	UV
Laser source	5 W
Coding format	
Focal length of high-speed scanning head	from 80 mm to 480 mm
Marking range of high-speed scanning head	from min. 55x55 mm ² to max. 330x330 mm ²
Advanced features	Aiming beam, Aim & Code
User interface	
User interface	Web user interface, multiple parallel access points, optional 10.1" TouchPanel
Interface options	Domino Cloud Interface (DCI), Domino Coding Automation
System Specifications	
Protection rating	Laser head: IP65* Controller: IP55
Operating temperature	5 °C – 40 °C
Ambient humidity	20–80% non-condensing
Power supply	Multi-voltage 90 – 264 V, 50/60 Hz
Inputs and outputs, interfaces	
Inputs/outputs	Multiple inputs and outputs are available, e.g., extractor, encoder, product detection (NPN, PNP), signal and interlocks, standard GPIO, additional optional GPIO available.
Interfaces	Ethernet, USB, protocollo Dynamark, EtherNet/IP™
Options	
Accessories	Extraction, air nozzle for cleaning lenses, multiple brackets, cables and mounting brackets
Application certifications	CE**, UKCA, CB / Conforme ai requisiti: NRTL, RoHS, FDA, EMC, FCC

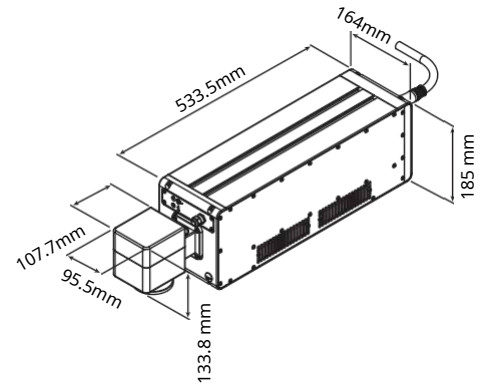
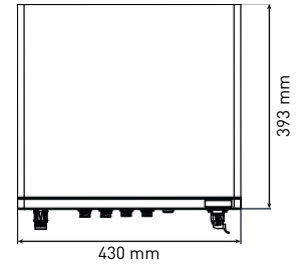
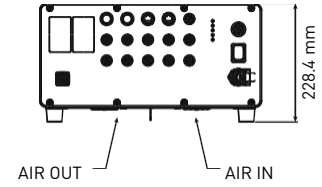

* Excluding the cooling section containing the fan and heat sink

** Partially completed machine in accordance with the Machinery Directive (2006/42/EC), CE marking in accordance with RoHS (2011/65/EU) and EMC (2014/30/EU)



OPERATIONAL FLEXIBILITY AND CUSTOMIZATION

- Traceability support with serialization, sequential, and batch numbering data. Synchronized clock / Network Time Protocol (NTP) support.
- Wide range of scan head orientations, including a 360° rotatable variant. Over 50 beam orientation variants. Additional support for customization and solution integration.



DISCOVER NIMAX DIGITAL INNOVATIONS



Line Strategy is the application that gives you full control of your production line from a single workstation



MyNimax Service Portal is your central platform for managing your Nimax machine fleet